

BOSCH

Invented for life

LTC 9210, LTC 9212, LTC 9213, and LTC 9223 Indoor/Outdoor Mounting Equipment



- ▶ **Maximum load: 9 kg (20 lb)**
- ▶ **Attractive Appearance**
- ▶ **Versatile Design**
- ▶ **Adjustable Mount Heads**
- ▶ **Lightweight**
- ▶ **Corrosion-Resistant Finish**

This series of indoor/outdoor mounting equipment is designed for fixed camera or camera housing installations up to a rated load of 9 kg (20 lb). All models are made of lightweight aluminum, and feature welded construction, providing an extremely rigid camera mount. All mounts come fully assembled.

The LTC 9210/00 is a 200-mm (8-inch) column mount, constructed of 38mm (1.5-inch) OD aluminum tubing with a welded surface mounting flange. An adjustable head is included for mounting a camera or housing. The adjustable head employs hex head screws and friction washers. The top mounting plate includes three (3) mounting holes for easy installation.

The LTC 9223/00 column mount is similar to the LTC 9210/00, but with a height of 610-mm (24-inch). The LTC 9212/00 is a 300-mm (12-inch) wall mount constructed of 38 mm (1.5-inch) OD aluminum tubing, with a welded surface mounting flange. This unit includes an adjustable head, mounted on a 90 degree angle bend, to permit mounting of a camera or housing. The adjustable head employs hex head screws, friction washers, and three (3) mounting holes for easy installation.

The LTC 9213/01 is a pole mount adaptor bracket, which facilitates mounting of the LTC 9212/00 mount and LTC 9215 Series Feed-through mounts, to a 3- to 15-inch diameter pole. Stainless steel straps are included for ease of mounting.

Installation/Configuration Notes

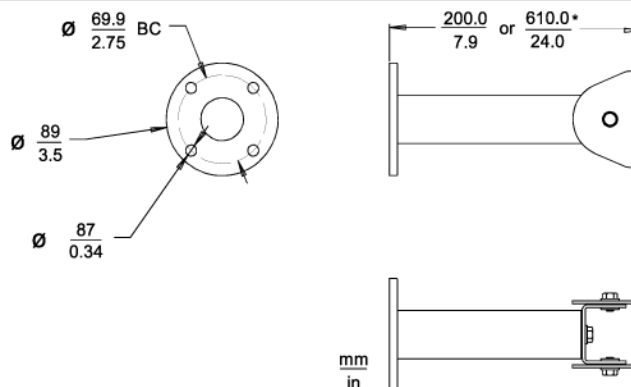

LTC 9210/00 Column Mount, 200 mm (8 inch)
LTC 9223/00 Column Mount, 610 mm (24 inch)

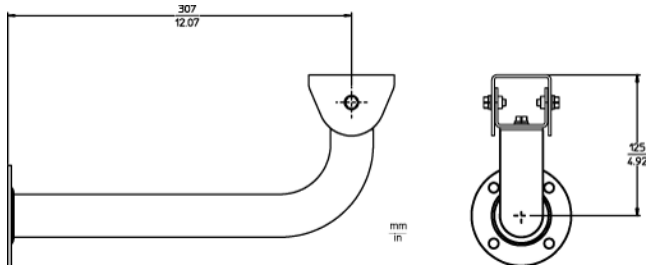

LTC 9212/00 Wall Mount, 300 mm (12 inch)

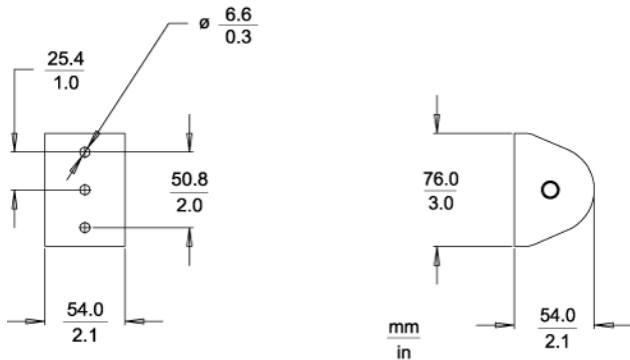

Dimensional Outline for adjustable head

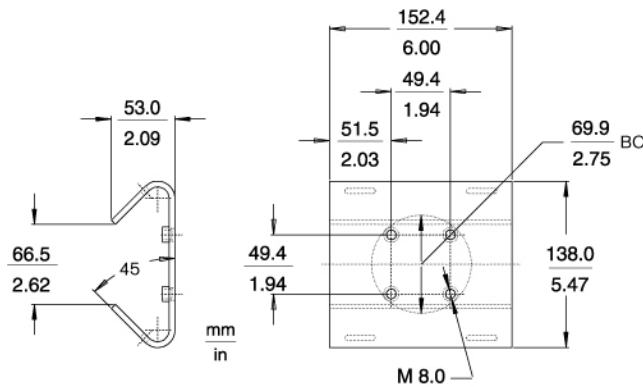

LTC 9213/01 Pole Mount Adapter

LTC 9210/00 20-mm (8-inch)

Column Mount

LTC 9223/00 610-mm (24-inch)

Column Mount

Approx. Weights

LTC 9210/00 300 g (0.6 lb)

LTC 9223/00 544 g (1.2 lb)

LTC 9213/01 Pole Mount Adapter

Mounting Hardware Two (2), 1.5 m (5 ft) stainless steel straps, (2) banding clips, (4) hex head cap screws, and (4) lockwashers are furnished with unit.

Options TC9311PM3T strapping tool available. Refer to Data Sheet for Accessories For Domed Housings.

Approx. Weight 850 g (1.9 lb)

Ordering Information

LTC 9210/00 Column Mount for 8-inch, 9 kg (20 lb) max load, light gray finish	LTC 9210/00
LTC 9212/00 Wall Mount for 12-inch, 9 kg (20 lb) max load, for LTC938x and LTC 948x series housings, light gray finish	LTC 9212/00
LTC 9223/00 Column Mount for 24-inch, 9 kg (20 lb) max load, light gray finish	LTC 9223/00
LTC 9213/01 Pole Mount Adapter for LTC 9210, LTC 9212 and LTC 9215, light gray finish	LTC 9213/01

Technical Specifications

LTC 9210/00, LTC 9212/00, LTC 9223/00, LTC 9213/01

Indoor/Outdoor Mounts

Maximum Load 9 kg (20 lb)

Mounting Head Adjustable 360° pan, 180° tilt (N/A for LTC 9213/01)

Finish Light gray

Europe, Middle East, Africa:
Bosch Security Systems B.V.
P.O. Box 80002
5600 JB Eindhoven, The Netherlands
Phone: + 31 40 2577 284
Fax: +31 40 2577 330
emea.securitysystems@bosch.com
www.boschsecurity.com

Americas:
Bosch Security Systems, Inc.
130 Perinton Parkway
Fairport, New York, 14450, USA
Phone: +1 800 289 0096
Fax: +1 585 223 9180
security.sales@us.bosch.com
www.boschsecurity.us

Asia-Pacific:
Bosch Security Systems Pte Ltd
38C Jalan Pemimpin
Singapore 577180
Phone: +65 6319 3450
Fax: +65 6319 3499
apr.securitysystems@bosch.com
www.boschsecurity.com

Represented by