

SONY®



SSC-CD Series

Fixed Mini-dome Cameras

www.sony.com/security

Reproducing Extremely Clear and Detailed Images, Sony Analog Mini-dome Cameras are Ideal for use in Commercial and Industrial Locations Such as Airports, Schools, Offices, and Many More!

Sony introduces a new line of fixed mini-dome cameras. All of these cameras employ highly sensitive imagers that produce amazingly clear and detailed images in a number of security and surveillance monitoring applications. For easy setup, they incorporate the Sony patented Ball-Joint Lens Mount mechanism, which provides quick and easy adjustment of the camera's viewing angle during installation.





The SSC-CD77/CD77P and SSC-CD75/CD75P are vandal-resistant mini-domes designed for either indoor or outdoor use. The SSC-CD77/CD77P camera incorporates the latest 1/3-type CCD with SuperExwave™ technology, which provides superb sensitivity. Designed for 24x7 operation, it also incorporates a Day/Night function that can produce detailed images even in zero lx^{*1} lighting conditions. The SSC-CD75/CD75P utilizes a 1/3-type Super HAD CCD™ to deliver high-quality color images and is perfect for security applications that do not require a day/night capability.

The SSC-CD49/CD49P and the SSC-CD45/CD45P are compact and discreet dome cameras designed for indoor security and surveillance monitoring applications. The SSC-CD49/CD49P camera incorporates unique Sony DynaView™ technology to provide a wide dynamic range when viewing high-contrast scenes with severe backlighting, such as a window or an entrance to a building.

Feature rich and flexible, this line of mini-dome cameras offers a wide variety of options to choose from. Each camera has a unique feature set, which allows users to choose exactly the right camera for their solution requirements.

*1 Zero lx means the absence of visible light to the naked eye. IR illuminators are required to operate at zero lx.

FEATURES AT A GLANCE

| | SSC-CD77/CD77P | SSC-CD75/CD75P | SSC-CD49/CD49P | SSC-CD45/CD45P |
|---|---|---|---|---|
| |  |  |  |  |
| CCD Imager | 1/3-type CCD With Super Exwave Technology | 1/3-type Super HAD CCD | 1/3-type CCD With Dynaview Technology | 1/3-type Super HAD CCD |
| Horizontal Resolution (TV lines) | 540 | 540 | 480 | 540 |
| Ruggedized Design (Vandal- and Weather-Resistant) | ○ | ○ | – | – |
| Wall- or Ceiling-Mountable | ○ | ○ | ○ | ○ |
| 3.6x Zoom, Auto-Iris Vari-Focal Lens | ○ | ○ | ○ | ○ |
| Sony Patented Ball-Joint Lens Mount | ○ | ○ | ○ | ○ |
| Day/Night Function | ○ | – | – | – |
| Wide Dynamic Range With DynaView | – | – | ○ | – |
| Backlight Compensation | ○ | ○ | ○ | ○ |
| Auto Tracing White Balance (ATW)/ATW pro | ○ | ○ | ○ | ○ |

FEATURES

Superb Picture Quality

SuperExwave Technology

SSC-CD77/CD77P

The SSC-CD77/CD77P incorporates an advanced 1/3-type CCD with SuperExwave technology that achieves extremely high sensitivity levels. This CCD imager provides a minimum illumination of 0.6 lx in color and 0.06 lx in B/W at F1.3, enabling the camera to capture clear and detailed images even under low light conditions.

Wide Dynamic Range With DynaView Technology

SSC-CD49/CD49P

The SSC-CD49/CD49P incorporates DynaView technology, which dramatically improves the camera's dynamic range by 128 times when compared to conventional cameras. This results in clear image reproduction, even in extreme high-contrast environments. The camera captures the same image twice – first with a normal shutter speed, and then with a high shutter speed. The dark areas captured at normal shutter speed and the bright areas captured at high shutter speed are then combined into one image using an advanced DSP LSI. Additionally, as these high-contrast scenes may have different lighting conditions, two white balance circuits are employed – one for normal shutter speed and the other for high shutter speed. This advanced technique reproduces high-contrast images with proper color.

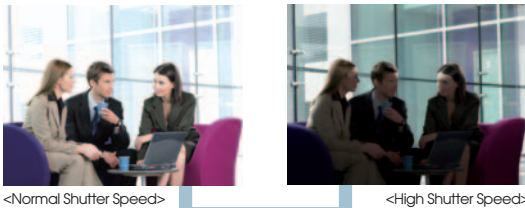

DynaView Technology

Super HAD™ CCD

SSC-CD75/CD75P SSC-CD45/CD45P

The SSC-CD75/CD75P and SSC-CD45/45P incorporate a 1/3-type Super HAD CCD that delivers high sensitivity levels and high picture quality for a number of monitoring applications. The minimum illumination of these cameras is 0.9 lx at F1.3.

High Horizontal Resolution

SSC-CD77/CD77P SSC-CD75/CD75P SSC-CD45/CD45P

The high-quality CCD imager of the SSC-CD77/CD77P/CD75/CD75P/CD45/CD45P in combination with the camera's state-of-the-art DSP technology, produces a high horizontal resolution of 540 TV lines for amazingly clear and detailed images.

Powerful 3.6x Zoom, Vari-focal Lens

These cameras come equipped with a 3.6x zoom, vari-focal lens that covers an extremely wide range of viewing angles from 100.8° (wide-angle) to 27.2° (telephoto). This feature provides installation flexibility for a number of different applications and locations.

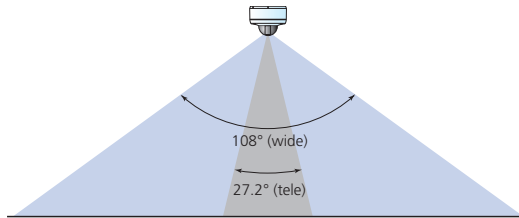

Flexible and Easy Installation

Wall- or Ceiling-mountable/Easy Viewing-angle Adjustment

These cameras can be easily wall- or ceiling-mounted^{*2}, for installation flexibility. Also, in addition to the BNC video output on the rear of the camera, a secondary video output (RCA phono jack) is provided on the front of the camera. This allows installers to monitor images during installation for accurate and quick adjustment of the focus and viewing-angle.

^{*2} Supplied bracket is required when the SSC-CD77/CD77P is wall- or ceiling-mounted.



Ceiling Surface Mount (SSC-CD45)



Ceiling Flush Mount (SSC-CD45/ YT-ICB45 Ceiling Mount Bracket)

Ball-Joint Lens Mount Technology

With the Sony patented Ball-Joint Lens Mount mechanism incorporated into the vari-focal lens of these cameras, the lens can be rotated freely in any direction. Unlike conventional cameras, it takes only one action to pan, tilt and rotate the imager/lens, allowing for quick and easy adjustment of the camera's viewing angle during installation.



Sony Patented Ball-Joint Lens Mount

Ruggedized Design

SSC-CD77/CD77P **SSC-CD75/CD75P**
The vandal-resistant SSC-CD77/CD77P and SSC-CD75/CD75P cameras are housed in a heavy-duty, aluminum die-cast enclosure with an impact-resistant polycarbonate dome. The camera complies with the IP66³ standard, and offers additional water resistance by using a special inner conduit for the camera cables. For cold-weather outdoor applications, the optional YT-HU75 Heater Unit is available. This allows the camera to be used in severe temperatures as low as -40 °C (-40 °F).

³ Ingress Protection (IP) standard is a system for numerically classifying the degree of protection provided by enclosures of electrical equipment against solid objects and liquids. IP66 means there is no ingress of dust and the equipment is protected against powerful water jets.

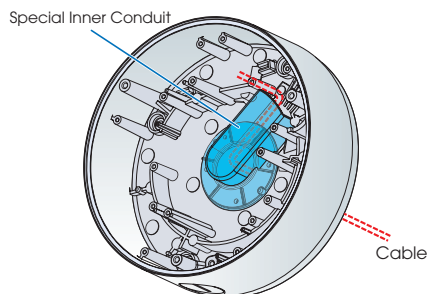

Water-resistant Design (SSC-CD77/CD75 inside)

Operational Flexibility

Day/Night Function

SSC-CD77/CD77P

The SNC-CD77/CD77P camera can switch from day mode (color) to night mode (B/W) by replacing its infrared-cut filter with a clear filter. Based on user presets, the camera can toggle between day mode and night mode when triggered by an external sensor, or automatically in response to surrounding light conditions. The camera can simultaneously switch to night mode and provide a trigger for near-IR illuminators via its external control port, allowing it to operate even in zero lx⁴ conditions.

⁴ Zero lx means the absence of visible light to the naked eye. IR illuminators are required to operate at zero lx.

Other Convenient Features

Backlight Compensation (BLC)

SSC-CD77/CD77P **SSC-CD75/CD75P** **SSC-CD45/CD45P**

Unwanted backlight can often cast a shadow in front of the subject of an image, making it appear dark to the camera. The BLC function incorporated in the SSC-CD77/CD77P/CD75/CD75P/CD45/CD45P cameras automatically compensates for such conditions, making the subject more visible.

Automatic Gain Control (AGC)

These cameras are equipped with an advanced AGC function. This automatically boosts the camera gain up to 24 dB, allowing operators monitoring the image to distinguish the subject more easily in low light conditions.

Auto Tracing White Balance (ATW)/ATW Pro

ATW is a feature that automatically adjusts the camera's white balance to adapt to changing light conditions. With ATW, these cameras can compensate for a color temperature range of between 2,000 K and 10,000 K, allowing for operation under a variety of lighting conditions, including common outdoor light sources such as high pressure sodium vapor lamp. When operating under natural light, incandescent lamps, or fluorescent light sources, ATW Pro – which compensates for a color temperature range of between 2,500 K and 6,000 K – is ideal for reproducing color images closer to what we see with our eyes.

AC Line Lock/Internal Line Lock

These cameras feature both an AC line lock and an internal line lock for synchronization. The AC line lock is ideal in multi-camera operations, as it synchronizes all cameras connected to the same power line. This helps to prevent the video from rolling vertically when switching between cameras. The vertical phase can be adjusted by ± 90 degrees.

Flexible Power Operation

These cameras offer a choice of two types of power: 24 V AC or 12 V DC. The camera automatically adapts to whichever power source is used, making installation fast and effective.

SYSTEM CONFIGURATIONS

Single Camera Operation

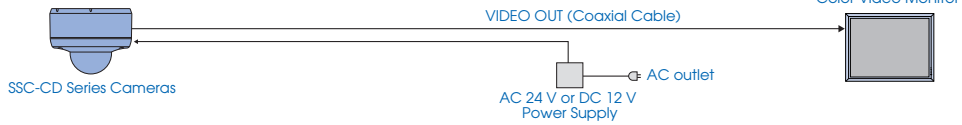

Multiple Camera Operation

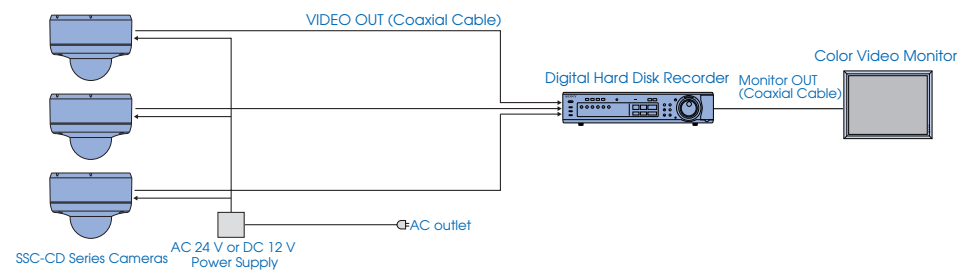

Multiple Camera Operation over LAN

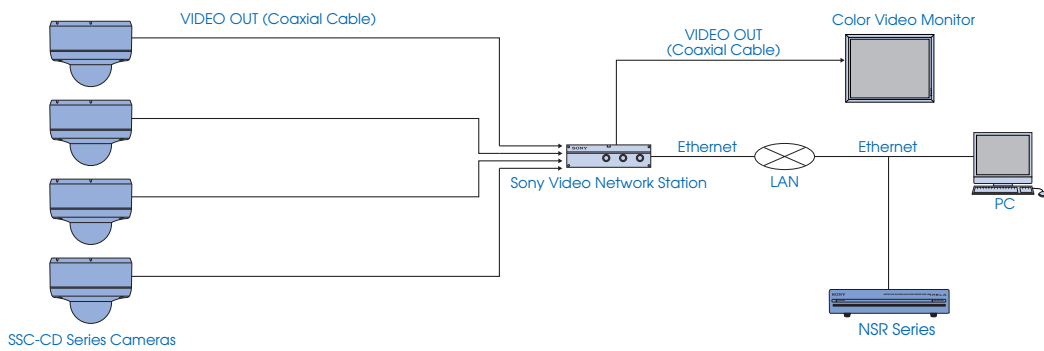

DIMENSIONS

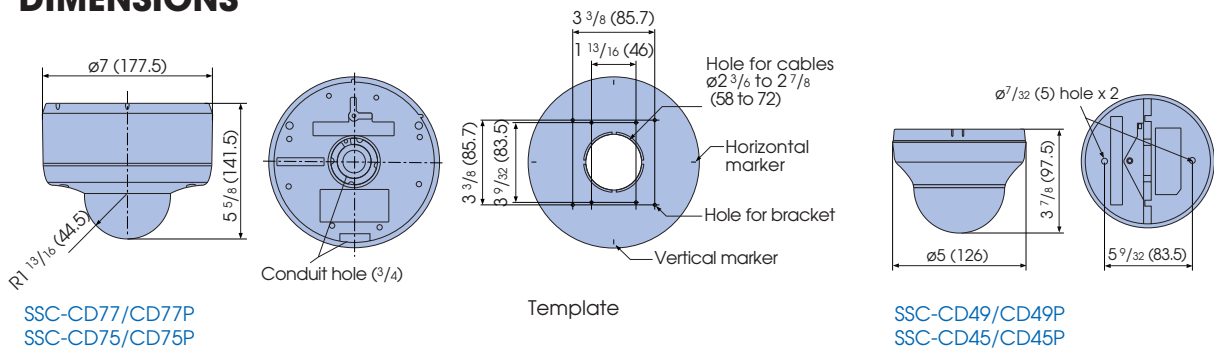

Unit: inches (mm)

OPTIONAL ACCESSORIES



YT-ICB45
In-Ceiling Mount Bracket



YT-HU75 Heater Unit

SSC-CD77/CD77P
SSC-CD75/CD75P

SPECIFICATIONS

| | SSC-CD77 | SSC-CD77P | SSC-CD75 | SSC-CD75P |
|------------------------------------|---|---------------------|--|---------------------|
| Camera | | | | |
| Image device | 1/3-type CCD with SuperExwave Technology | | 1/3-type CCD with Super HAD Technology | |
| Number of effective pixels (H x V) | 380,000 (768 x 494) | 440,000 (752 x 582) | 380,000 (768 x 494) | 440,000 (752 x 582) |
| Gain control | ON/OFF | | | |
| White balance mode | ATW/ATW Pro | | | |
| Lens type | Auto iris vari-focal lens | | | |
| Zoom ratio | 3.6x optical zoom (1.5x digital zoom) | | | |
| Horizontal viewing angle | 100.8° to 27.7° | | | |
| Focal length | f=2.8 to 10.0 mm | | | |
| Backlight compensation | ON/OFF | | | |
| Day/Night function | Auto/External control | | - | |
| Analog video output | BNC x1, 1.0 Vp-p, 75 Ω, RCA x 1 | | | |
| Signal system | NTSC (Composite) | PAL (Composite) | NTSC (Composite) | PAL (Composite) |
| Sync system | AC Line Lock/Internal Lock | | | |
| Horizontal resolution | 540 TV lines | | | |
| S/N ratio | more than 50 dB (AGC ON/Weight ON) | | | |
| Min. illumination | Color: 0.6 lx (50IRE, F1.3, AGC ON) B&W: 0.06 lx (50IRE, F1.3, AGC ON) | | 0.9 lx (50IRE, F1.3, AGC ON) | |
| General | | | | |
| Weight | approx. 3 lb 11 oz (1.75 kg) | | | |
| Dimensions (Ø x H) | approx. 7 x 5 5/8 inches (177 x 141 mm) | | | |
| Power requirements | AC24V/DC12V | | | |
| Power consumption | 4 W max. (16 W with heater option) | | | |
| Operating temperature | -4 to 122 °F (-20 to 50 °C) -40 to 122 °F (-40 to 50 °C) w/heater unit | | | |
| Storage temperature | -40 to 140 °F (-40 to 60 °C) | | | |
| Supplied accessories | | | | |
| | Bracket, Template, Torx wrench, M4 screws (4), Wire rope, M4 shoulder screw, Operation instructions | | | |

| | SSC-CD49 | SSC-CD49P | SSC-CD45 | SSC-CD45P |
|------------------------------------|--|---------------------|--|---------------------|
| Camera | | | | |
| Image device | 1/3-type CCD with DynaView technology | | 1/3-type CCD with Super HAD Technology | |
| Number of effective pixels (H x V) | 380,000 (768 x 494) | 440,000 (752 x 582) | 380,000 (768 x 494) | 440,000 (752 x 582) |
| Gain control | ON/OFF | | | |
| White balance mode | ATW/ATW Pro | | | |
| Lens type | Auto iris vari-focal lens | | | |
| Zoom ratio | 3.6x optical zoom (1.5x digital zoom) | | | |
| Horizontal viewing angle | 100.8° to 27.7° | | | |
| Focal length | f=2.8 to 10.0 mm | | | |
| Backlight compensation | DynaView ON/OFF | | ON/OFF | |
| Analog video output | BNC x1, 1.0 Vp-p, 75 Ω, RCA x 1 | | | |
| Signal system | NTSC (Composite) | PAL (Composite) | NTSC (Composite) | PAL (Composite) |
| Sync system | AC Line Lock/Internal Lock | | | |
| Horizontal resolution | 480 TV lines | | 540 TV lines | |
| S/N ratio | more than 50 dB (AGC ON/Weight ON) | | | |
| Min. illumination | Color: 0.7 lx (50IRE, F1.3, AGC ON) | | 0.9 lx (50IRE, F1.3, AGC ON) | |
| General | | | | |
| Weight | approx. 15 lb (440 g) | | | |
| Dimensions (Ø x H) | approx. 5 x 3 7/8 inches (126 x 97 mm) | | | |
| Power requirements | AC24V/DC12V | | | |
| Power consumption | 4.2 W max. | | 4.0 W max. | |
| Operating temperature | -4 to 122 °F (-20 to 50 °C) | | | |
| Storage temperature | -40 to 140 °F (-40 to 60 °C) | | | |
| Supplied accessories | | | | |
| | Template, Wire rope, M4 shoulder screw, Operation instructions | | | |

SONY

Sony Electronics Inc.
One Sony Drive
Park Ridge, NJ 07656
www.sony.com/security

© 2007 Sony Electronics Inc. All rights reserved.
Reproduction in whole or in part without written permission is prohibited.
Features and specifications are subject to change without notice.
All non-metric weights and measurements are approximate.
Some images in this brochure are simulated.
Sony, SuperExwave, Super HAD, and DynaView are trademarks of Sony.
All other trademarks are the property of their respective owners.